

**Dados do Subwoofer**

<b>Marca :</b>	<b>Bravox</b>	<b>Modelo :</b>	<b>UXP-12D2</b>
EBP :	<b>59,34</b>	Diâmetro:	<b>12 Polegadas</b>
Impedância:	<b>2X2 Ohms</b>	Qms:	<b>5,3600</b>
Potência:	<b>400 Watts RMS</b>	Qes:	<b>0,5393</b>
Eficiência:	<b>88,4 dB/w /m</b>	Qts:	<b>0,49</b>
Fs:	<b>32 Hz</b>	Re:	<b>3,60 Ohms</b>
Vas:	<b>2,438 ft³</b>	Vd:	<b>0,3619 litros</b>
Vas:	<b>68,998 litros</b>	Sd:	<b>0,0452 m²</b>
Xmax:	<b>8,00 mm</b>	No:	<b>0,40 %</b>
		Volume deslocado pelo subwoofer:	<b>2,70 litros</b>

**Caixa Acústica - Selada Normal**

Qtc :	<b>0,89</b>	Volume VR :	<b>30,0117 litros</b>	Maior medida ::	<b>dS</b> Medid metros
Quantidade de Subs:	<b>1</b>		<b>1,0605 ft³</b>		
		Vol. Total:	<b>32,7117 litros</b>		
			<b>1,1559 ft³</b>	Pico :	<b>0,6348 dB</b>
		Freq. p/ análise:	<b>30 Hz</b>	Alfa :	<b>2,30 dB</b>
		Pe max :	<b>182,10 watts</b>	Fc :	<b>58,1224 Hz</b>
		Pe max p/ Freq.:	<b>138,17 watts</b>	F3 :	<b>48,5265 Hz</b>
		SPL Max. :	<b>98,54 dB</b>	FXmax :	<b>35,2955 Hz</b>
		SPL Térmico :	<b>103,56 dB</b>	FGmax :	<b>95,7124 Hz</b>
		SPL Pico :	<b>114,47 dB</b>		
		SPL Carro :	<b>116,75 dB</b>		

**Desenho**

Formato: **Trapézio**      Espessura da madeira: **15,00 mm**

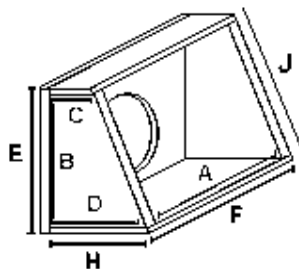

<b>A :</b>	<b>39,29 cm</b>
<b>B :</b>	<b>37,00 cm</b>
<b>C :</b>	<b>15,00 cm</b>
<b>D :</b>	<b>30,00 cm</b>
<b>E :</b>	<b>40,00 cm</b>
<b>F :</b>	<b>42,29 cm</b>
<b>G :</b>	cm
<b>H :</b>	<b>30,90 cm</b>
<b>J :</b>	<b>43,94 cm</b>

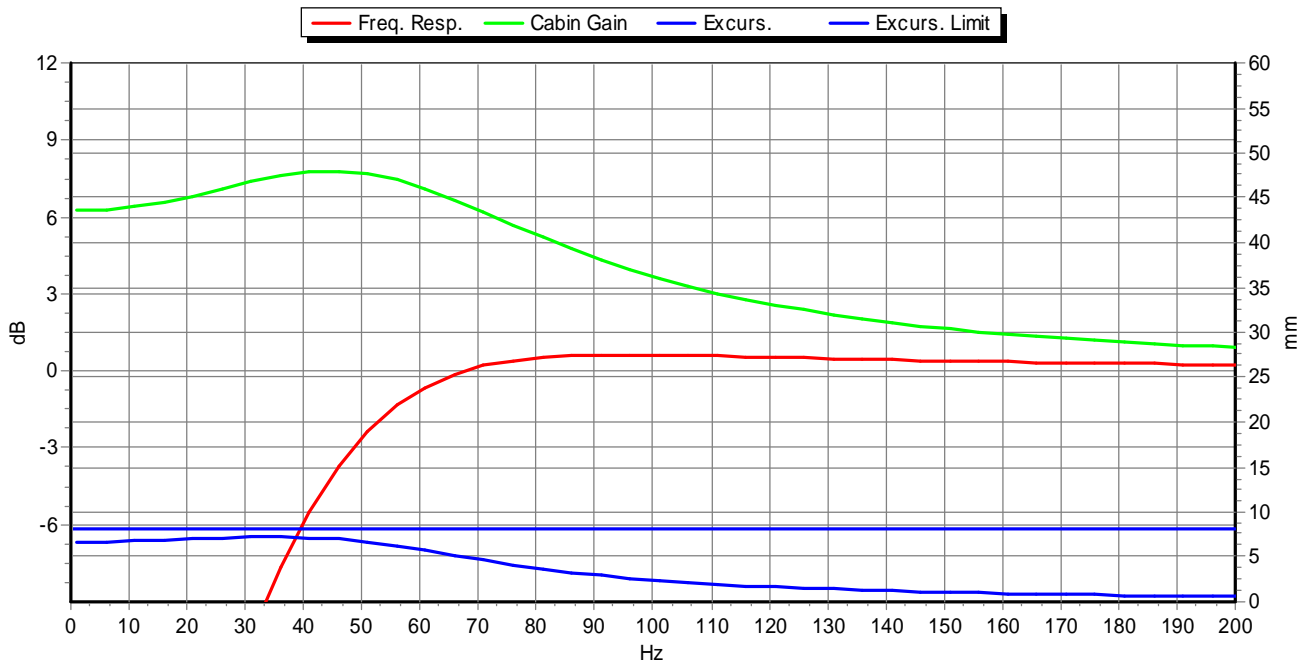

Cortes / View

Selada Normal

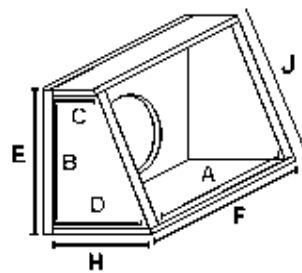
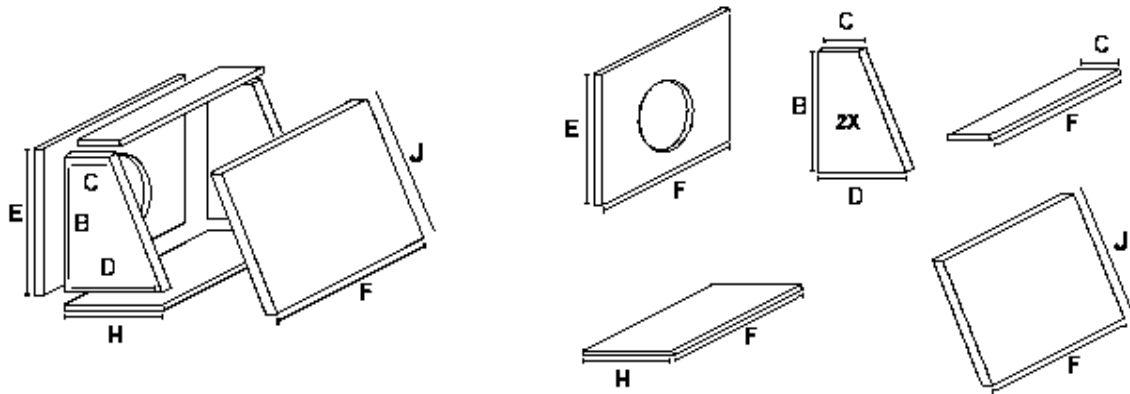

A :	39,29 cm
B :	37,00 cm
C :	15,00 cm
D :	30,00 cm
E :	40,00 cm
F :	42,29 cm
G :	cm
H :	30,90 cm
J :	43,94 cm